

# WHELEN<sup>®</sup>

ENGINEERING COMPANY INC.

51 Winthrop Road,  
Chester, Connecticut 06412-0684

Phone: (860) 526-9504

Fax: (860) 526-4078

Internet: [www.whelen.com](http://www.whelen.com)

Sales e-mail: [autosale@whelen.com](mailto:autosale@whelen.com)

Canadian Sales e-mail: [autocan@whelen.com](mailto:autocan@whelen.com)

Customer Service e-mail: [custserv@whelen.com](mailto:custserv@whelen.com)

## Installation Guide: Justice<sup>®</sup> Competitor Series Lightbar

### Safety First

This document provides all the necessary information to allow your Whelen product to be properly and safely installed. Before beginning the installation and/or operation of your new product, the installation technician and operator must read this manual completely. Important information is contained herein that could prevent serious injury or damage.

- Proper installation of this product requires the installer to have a good understanding of automotive electronics, systems and procedures.
- If mounting this product requires drilling holes, the installer **MUST** be sure that no vehicle components or other vital parts could be damaged by the drilling process. Check both sides of the mounting surface before drilling begins. Also de-burr any holes and remove any metal shards or remnants. Install grommets into all wire passage holes.
- If this manual states that this product may be mounted with suction cups, magnets, tape or Velcro<sup>®</sup>, clean the mounting surface with a 50/50 mix of isopropyl alcohol and water and dry thoroughly.
- Do not install this product or route any wires in the deployment area of your air bag. Equipment mounted or located in the air bag deployment area will damage or reduce the effectiveness of the air bag, or become a projectile that could cause serious personal injury or death. Refer to your vehicle owner's manual for the air bag deployment area. The User/Installer assumes full responsibility to determine proper mounting location, based on providing ultimate safety to all passengers inside the vehicle.
- For this product to operate at optimum efficiency, a good electrical connection to chassis ground must be made. The recommended procedure requires the product ground wire to be connected directly to the **NEGATIVE (-)** battery post.
- If this product uses a remote device to activate or control this product, make sure that this control is located in an area that allows both the vehicle and the control to be operated safely in any driving condition.
- Do not attempt to activate or control this device in a hazardous driving situation.
- This product contains either strobe light(s), halogen light(s), high-intensity LEDs or a combination of these lights. Do not stare directly into these lights. Momentary blindness and/or eye damage could result.
- Use only soap and water to clean the outer lens. Use of other chemicals could result in premature lens cracking (crazing) and discoloration. Lenses in this condition have significantly reduced effectiveness and should be replaced immediately. Inspect and operate this product regularly to confirm its proper operation and mounting condition. Do not use a pressure washer to clean this product.
- It is recommended that these instructions be stored in a safe place and referred to when performing maintenance and/or reinstallation of this product.
- **FAILURE TO FOLLOW THESE SAFETY PRECAUTIONS AND INSTRUCTIONS COULD RESULT IN DAMAGE TO THE PRODUCT OR VEHICLE AND/OR SERIOUS INJURY TO YOU AND YOUR PASSENGERS!**

**For warranty information regarding this product, visit [www.whelen.com/warranty](http://www.whelen.com/warranty)**

**IMPORTANT!** The lightbar should be a minimum of 16" from any radio antennas!

**Permanent Mounting:**

1. Locate the mounting foot and mounting plate included with your lightbar. If not already present, install the mounting plate onto the mounting foot. When properly positioned, this plate is centered from side-to-side on the mounting foot.
2. Flip lightbar upside-down to expose bottom of extrusion and place mounting foot onto extrusion.
3. Rotate the mounting foot 90° in a counter-clockwise direction. Make sure that the edges of the mounting foot swing into position under the extrusion mounting lip.
4. Repeat this procedure for the remaining mounting foot and return the lightbar to its right side-up position.
5. Position the lightbar onto the vehicle roof in the desired mounting location. One often selected location is directly above the B-pillars. This area is the strongest part of the roof. Refer to your lightbar manual for your lightbars cable exit location, to be sure that the lightbar is facing the proper direction.
6. Adjust the two mounting feet outwards so that they are as close to the edge of the roof as possible. Make sure that both mounting feet are in full contact with the roof (See below). Be sure that there is no less than 1/2" clearance between the roof and the lightbar at their closest point. When the mounting feet are in their proper position, lightly tighten the mounting foot allen head set screws.
7. Turn the lightbar upside-down and firmly tighten all of the set screws from step 6 (2 or 4 per side).
8. Note that on the adjustable foot, use the hole in the pad as a guide to drill the two holes into the mounting foot at the locations shown.
9. Place the lightbar in its final mounting position on the vehicle, mark the mounting hole locations off onto the mounting surface, remove the lightbar and drill the mounting holes.
10. Place the lightbar back onto the vehicle lined up with the mounting holes and secure the mounting feet to the vehicle using the supplied hardware.

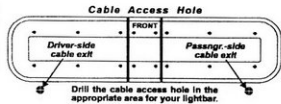
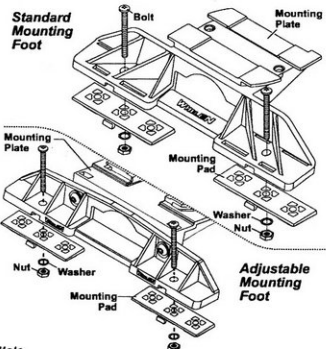

**NOTE:** Unless otherwise specified, the lightbar mounting feet must be sitting as close to the edge of the roof as possible. They must also be in full contact with the roof and not be hanging off the edge.

**IMPORTANT:** For strap mounting, be sure you have the right sized lightbar for your vehicle. The bar should be approximately the same width as the vehicle roof. If too large or small it will not mount properly and may come loose during driving.

**Slide Bolt Mounting (Permanent):**

1. Position the slide bolt mounting plates onto the bottom of the lightbar extrusion. These plates rotate into position the same way as the mounting foot. Position the plates as far outward as possible (if a 3rd mounting plate is used, it should be positioned under the center of the lightbar).
2. Secure the plates to the extrusion using the set screws provided.
3. Position the lightbar onto the vehicle and mark the mounting bolt locations. Drill the necessary mounting holes using an appropriately sized drill bit sized for a 1/2" bolt.

**Strap Mounting:**

1. Locate the mounting foot, mounting plate and tinnerman plate included with your lightbar. If not already present, install the mounting plate onto the mounting foot. When properly positioned, this plate is centered from side-to-side on the mounting foot.
2. Flip the lightbar upside-down to expose the bottom of the extrusion and place the mounting foot onto the extrusion.
3. Rotate the mounting foot 90° in a counter-clockwise direction. Make sure that the edges of the mounting foot swing into position under the extrusion mounting lip. Install a tinnerman plate onto the extrusion in the same manner.
4. Repeat this procedure for the remaining mounting foot and tinnerman plate and return the lightbar to its right side-up position.
5. Position the lightbar onto the vehicle roof in the desired mounting location. One often selected location is directly above the B-pillars. This area is the strongest part of the roof. Refer to your lightbar manual for cable exit location, to be sure that the lightbar is facing the proper direction.
6. Adjust the two mounting feet outwards so that they are as close to the edge of the roof as possible. Both mounting feet must be in full contact with the roof. Be sure that there is no less than 1/2" clearance between the roof and the lightbar at their closest point. When the mounting feet are in their proper position, lightly tighten the mounting foot allen head set screws.
7. Return the lightbar to an upside-down position. Slide each tinnerman plate outwards until it is fully engaged with its corresponding mounting foot. With the mounting feet and tinnerman plates in their proper positions firmly tighten all of the set screws (2 or 4 per side). Flip the lightbar right side-up and return it to its mounting position.

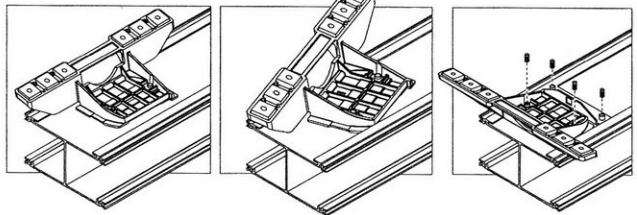

8. Open both drivers side doors. In the area directly below the mounting foot, carefully pull the drivers side weather-strip away from the vehicle. Remove enough so that the area where the mounting strap will be secured to the vehicle is exposed. Repeat procedure for passenger side.
  9. Insert the mounting strap through the mounting foot. Be sure that the strap fits flush against the area where it will be secured onto the vehicle. Insert the tension bolt through the mounting strap and into the tinerman nut on the tinerman plate. Tighten slightly with a long shafted, Phillips screwdriver. Repeat procedure for passenger side.
  10. If your mounting strap has mounting holes in the end of the strap, use these holes as a template to drill appropriately sized pilot holes through the strap and into the vehicle. Repeat for passenger side of the vehicle.
  11. Firmly tighten the tension bolts to secure the lightbar to the vehicle.
- NOTE: Model MKAJ is an adjustable mounting foot. On this model you may loosen the screws on the rear of the foot and adjust the angle of the lightbar. This feature can be used if the angle of the roof is not level with the road.**
- IMPORTANT: To adjust the leveling screws you must use a torque wrench set at 35 to 40 in./lbs.**

### Standard Mounting Foot / Model MKEZ

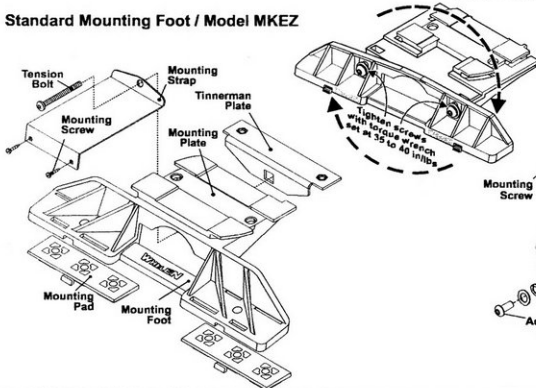

### Adjustable Mounting Foot / Model MKAJ

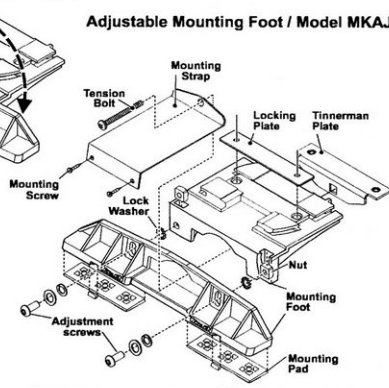

### 5" Mounting Foot

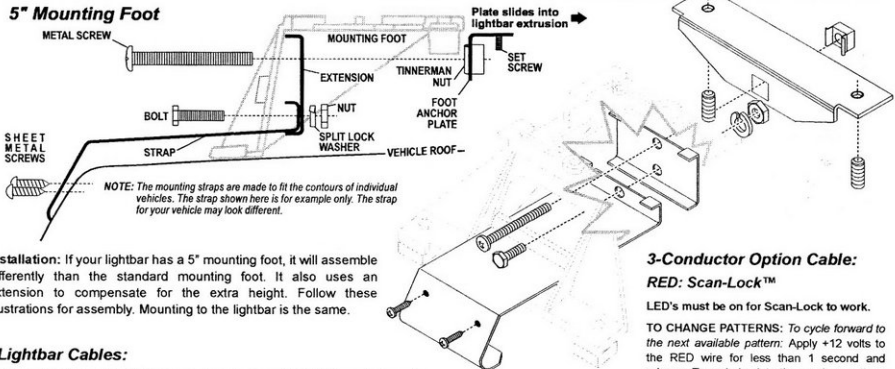

**Installation:** If your lightbar has a 5" mounting foot, it will assemble differently than the standard mounting foot. It also uses an extension to compensate for the extra height. Follow these illustrations for assembly. Mounting to the lightbar is the same.

### Lightbar Cables:

**Standard Lightbar:** This lightbar uses a 4-conductor cable for LEDs and a 6- and 3-conductor cable for options. There is also an option for Brake-Tail to connect to your brake lights. Extend the 3-, 4- and 6-conductor cables towards your switch panel. The instructions included with your switches will provide switch wiring information. The optional brake-tail cable connects to the brake lights.

Refer to the next page for wire designations and fusing.

**WARNING!** All Customer supplied wires that connect to the positive terminal of the battery must be sized to supply at least 125% of the maximum operating current and **FUSED** at the battery to carry that load. **DO NOT USE CIRCUIT BREAKERS WITH THIS PRODUCT!**

### 6 Conductor Option Cable:

- WHITE:** Apply +12 volts to activate the Take-downs or Worklight
- GREEN:** Apply +12 volts to activate the Passenger Side Alley lights
- RED:** Apply +12 volts to activate the Driver Side Alley light.
- BLUE:** Apply +12 volts to activate the Take-downs in flashing mode.

### 3-Conductor Option Cable:

**RED: Scan-Lock™**

LED's must be on for Scan-Lock to work.

**TO CHANGE PATTERNS:** To cycle forward to the next available pattern: Apply +12 volts to the RED wire for less than 1 second and release. To cycle back to the previous pattern: Apply +12 volts to the RED wire for more than 1 second and release.

**TO CHANGE THE DEFAULT PATTERN:** When the desired pattern is active, allow it to run for more than 5 seconds. The lighthead will now display this pattern when activated.

**TO RESTORE THE FACTORY DEFAULT PATTERN:** With power to the lightheads off, apply +12 volts to the RED wire. While still applying +12 volts to the RED wire, turn power to the lightheads back on. The factory default pattern should now be displayed.

A normally open momentary switch can be used to control Scan-Lock operation.

### IMPORTANT WARNING!

**CAUTION! DO NOT LOOK DIRECTLY AT THESE LEDs WHILE THEY ARE ON. MOMENTARY BLINDNESS AND/OR EYE DAMAGE COULD RESULT!**

**BLACK: Pattern Override**

Applying +12 volts to the BLACK wire while lightheads are activated will change the flash pattern to whatever "pattern override" is programmed for. To program the flash pattern activate the lightbar. Activate *pattern override* by applying +12 volts to the BLACK wire then select a flash pattern using the Scan-Lock™ procedure.

**IMPORTANT!** Before returning this vehicle to active service, visually confirm the proper operation of this product, as well as all vehicle components/equipment.

**IMPORTANT!** It is the responsibility of the installation technician to make sure that the installation and operation of this product will not interfere with or compromise the operation or efficiency of any vehicle equipment!

**Available Flash Patterns:**

- |                               |                                 |                                 |                              |
|-------------------------------|---------------------------------|---------------------------------|------------------------------|
| 1. ActionScan™                | 14. SingleFlash 75° Alt.        | 27. SingleFlash 90° Alt./Sync.  | 40. MicroBurst™ Sim          |
| 2. SignalAlert™ Alt.          | 15. SingleFlash 75° Alt./ASync  | 28. SingleFlash 90° Sim.        | 41. MicroBurst™ Alt./Sim.    |
| 3. SignalAlert™ Alt./ASync    | 16. SingleFlash 75° Sim.        | 29. SingleFlash 90° Alt./Sim    | 42. ActionFlash™ Alt.        |
| 4. SignalAlert™ Sim           | 17. SingleFlash 75° Alt. Sim.   | 30. SingleFlash 120° Alt.       | 43. ActionFlash™ Alt./ASync. |
| 5. SignalAlert™ Alt./Sim.     | 18. LongBurst™ Alt.             | 31. SingleFlash 120° Alt./Sync. | 44. ActionFlash™ Sim.        |
| 6. CometFlash® Alt.           | 19. LongBurst™ Alt./ASync.      | 32. SingleFlash 120° Sim        | 45. PingPong™ Alt.           |
| 7. CometFlash® Alt./ASync     | 20. LongBurst™ Sim.             | 33. SingleFlash 120° Alt./Sim.  | 46. PingPong™ Alt./ASync.    |
| 8. CometFlash® Sim            | 21. LongBurst™ Alt./Sim.        | 34. SingleFlash 300 Alt.        | 47. FilmFlam Alt.            |
| 9. CometFlash® Alt./Sim.      | 22. SingleFlash 60° Alt.        | 35. SingleFlash 300 Alt./Sync.  | 48. FilmFlam Alt./ASync.     |
| 10. DoubleFlash 75 Alt.       | 23. SingleFlash 60° Alt./ASync. | 36. SingleFlash 300 Sim.        | 49. ModuFlash™ Alt.          |
| 11. DoubleFlash 75 Alt./ASync | 24. SingleFlash 60° Sim.        | 37. SingleFlash 300 Alt./Sim    | 50. ModuFlash™ Alt./ASync.   |
| 12. DoubleFlash 75 Sim.       | 25. SingleFlash 60° Alt./Sim.   | 38. MicroBurst™ Alt.            | 51. ModuFlash™ Sim.          |
| 13. DoubleFlash 75 Alt./Sim.  | 26. SingleFlash 90° Alt.        | 39. MicroBurst™ Alt./ASync      | 52. ZigZag.                  |

Alt.= Alternating      Sim. = Simultaneous      Alt./Sim. = Alternating/Simultaneous      Alt./ASync. = Alternating/ASynchronous\* = California Title IIIX Compliant

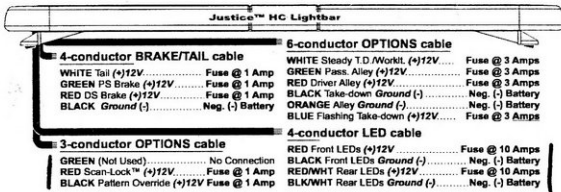

**LR11 LED / Angle Adjustment**

The LR11 mounting brackets angle is adjustable. An alley light is shown here.

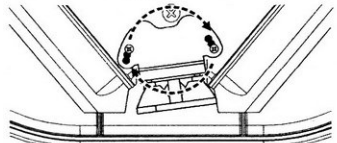

The LR11 can be adjusted up to 7.5° to either side.

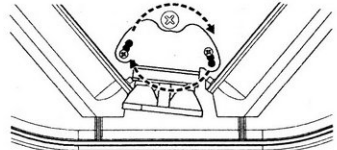

**LR11 / Removal & Installation / Alley Light**

